

# VILLA AL

## INSTRUCCIONES DE MONTAJE

## MOUNTING INSTRUCTIONS

## MONTAGEANLEITUNG

## INSTRUCTIONS DE MONTAGE



|          | Serie         | Material       | LED SMD | Light | kg      | Light     | Tc      |
|----------|---------------|----------------|---------|-------|---------|-----------|---------|
| VILLA AL | VIAL.1M.04500 | A445 B445 H780 | 24W     | 28W   | 7.00 Kg | 0.31-0.09 | Tc 70°C |
| VILLA AL | VIAL.1M.05000 | A445 B445 H780 | 32W     | 35W   | 7.00 Kg | 0.39-0.11 | Tc 70°C |
| VILLA AL | VIAL.1M.05500 | A445 B445 H780 | 34W     | 37W   | 7.00 Kg | 0.41-0.12 | Tc 70°C |
| VILLA AL | VIAL.1M.06000 | A445 B445 H780 | 40W     | 44W   | 7.00 Kg | 0.49-0.14 | Tc 70°C |
| VILLA AL | VIAL.1M.06500 | A445 B445 H780 | 44W     | 50W   | 7.00 Kg | 0.25-0.16 | Tc 70°C |
| VILLA AL | VIAL.2M.09000 | A445 B445 H780 | 59W     | 64W   | 8.25 Kg | 0.71-0.21 | Tc 70°C |
| VILLA AL | VIAL.2M.11000 | A445 B445 H780 | 78W     | 85W   | 8.25 Kg | 0.94-0.28 | Tc 70°C |

|                        | IP67 | IK10 | Ref.              | V        | f          | Tw       | Tc              |
|------------------------|------|------|-------------------|----------|------------|----------|-----------------|
| DRIVER (VIAL.1M.04500) |      |      | LECFAM0042CFNT007 | 90-305 V | 0.31-0.09A | 50/60 Hz | Tw 80°C Tc 70°C |
| DRIVER (VIAL.1M.05000) |      |      | LECFAM0045CFNT000 | 90-305 V | 0.39-0.11A | 50/60 Hz | Tw 80°C Tc 70°C |
| DRIVER (VIAL.1M.05500) |      |      | LECFAM0048CFNT001 | 90-305 V | 0.41-0.12A | 50/60 Hz | Tw 80°C Tc 70°C |
| DRIVER (VIAL.1M.06000) |      |      | LECFAM0042CFNT000 | 90-305 V | 0.49-0.14A | 50/60 Hz | Tw 80°C Tc 70°C |
| DRIVER (VIAL.1M.05000) |      |      | LECLAY0070CFNT000 | 90-305 V | 0.25-0.16A | 50/60 Hz | Tw 80°C Tc 70°C |
| DRIVER (VIAL.2M.09000) |      |      | LECFAM0042CFNT004 | 90-305 V | 0.71-0.21A | 50/60 Hz | Tw 80°C Tc 70°C |
| DRIVER (VIAL.2M.11000) |      |      | LECFAM0048CFNT010 | 90-305 V | 0.94-0.28A | 50/60 Hz | Tw 80°C Tc 70°C |



Polígono Industrial El Olivar, Copejadores N 2 · 11160 Barbate (Cádiz) España-Spain  
Tel.: +34 956 454 130  
[comercial@lecsl.com](mailto:comercial@lecsl.com) | [www.lecsl.com](http://www.lecsl.com)



“Empresa certificada en diseño y fabricación de luminarias LED”

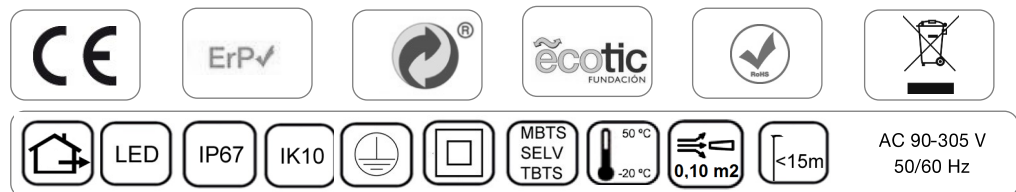

1/2



**ES** Esta luminaria está destinada exclusivamente a iluminación y debe ser instalada de acuerdo con las pertinentes normas nacionales. Cualquier otro uso o instalación no se considerará "acorde a las instrucciones de montaje".

**EN** The luminaire is used exclusively for lighting and to be installed in accordance with the national installation regulations. Any other use or installation is regarded as "not according to instructions".

**DE** Die Leuchte dient ausschließlich der Beleuchtung und ist entsprechend den nationalen Errichtungsbestimmungen zu installieren. Eine andere Nutzung oder ein anderer Einbau gilt als „nicht bestimmungsgemäß“.

**FR** Le luminaire sert uniquement à l'éclairage et doit être installé conformément aux prescriptions nationales en matière d'installation. Toute autre utilisation ou installation est considérée comme "non conforme".



**ES** El montaje y la puesta en marcha solo puede ser realizado por personal especialmente autorizado.

**EN** Installation and commissioning may only be carried out by authorized specialist.

**DE** Die Montage und Inbetriebnahme darf nur von autorisiertem Fachpersonal durchgeführt werden.

**FR** L'installation et la mise en service doivent obligatoirement être effectuées par des techniciens.



**ES** Realizar periódicamente una limpieza de la óptica con un paño húmedo.

**EN** Clean the optics with a damp cloth

**DE** Reinigen Sie die Optik mit einem feuchten Tuch.

**FR** Nettoyer périodiquement les optiques avec un chiffon humide.

**ES** Cable de alimentación tipo Y. Si el cable flexible o cordón de esta luminaria está dañado, debe sustituirse por un cable flexible o cordón especial que suministre exclusivamente el fabricante o su servicio técnico

**FR** Le câble d'alimentation type Y. Si le câble flexible ou le cordon de ce luminaire est endommagé, vous devez le remplacer par un câble flexible ou un cordon spécial qui est fourni uniquement par le fabricant ou par son département technique.

**EN** Power cord type-Y. If the flexible cable or cord of this luminaire is damaged, it must be replaced with a flexible cable or a special cord exclusively supplied by the manufacturer or its technical support.

**DE** Anschlussleitung Typ Y. Wenn die flexible Leitung dieser Leuchte beschädigt ist, muss es mit einem flexiblen Kabel oder einem Spezialkabel ausschließlich vom Hersteller oder dessen technischen Support versorgt ersetzt werden.

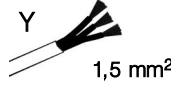

VAC

DRIVER

matriz 1  
matriz 2



2/2

1

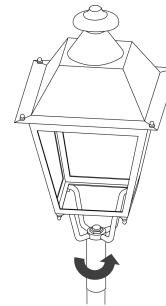

Ø M-16  
114Nm

2

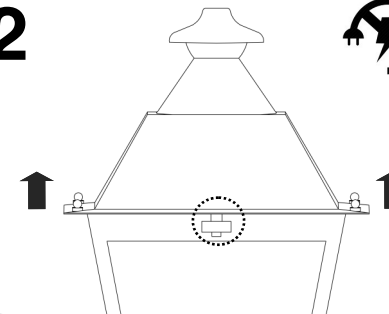

3

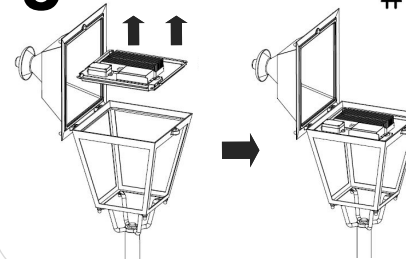

4

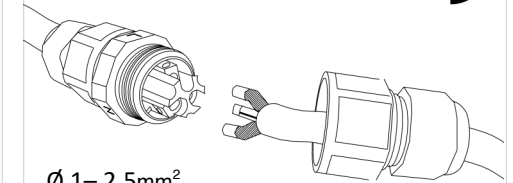

Ø 1-2,5mm²

5

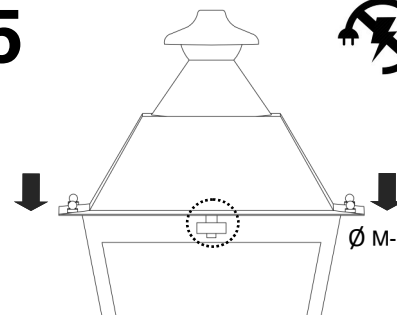

Ø M-5

6

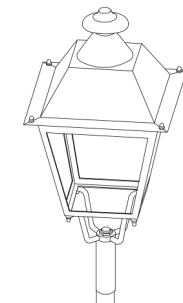

Ø M-5