



**ES** El montaje y la puesta en marcha solo puede ser realizado por personal especialmente autorizado. La fuente de luz de esta luminaria debe reemplazarse únicamente por el fabricante, su servicio técnico o persona cualificada equivalente.

**FR** L'installation et la mise en service doivent obligatoirement être effectuées par des techniciens. La source lumineuse de ce luminaire ne doit être remplacée que par le fabricant, son service technique ou une personne qualifiée équivalente.

**EN** Installation and commissioning may only be carried out by authorized specialist. The light source of this luminaire should be replaced only by the manufacturer, its technical service or equivalent qualified person.

**DE** Die Montage und Inbetriebnahme darf nur von autorisiertem Fachpersonal durchgeführt werden. Die Lichtquelle dieser Leuchte darf nur vom Hersteller, seinem technischen Kundendienst oder einer gleichwertigen qualifizierten Person ausgetauscht werden.



**ES** Realizar periódicamente una limpieza de la óptica con un paño húmedo.

**EN** Clean the optics with a damp cloth

**DE** Reinigen Sie die Optik mit einem feuchten Tuch.

**FR** Nettoyer périodiquement les optiques avec un chiffon humide.

**ES** Cable de alimentación tipo Y. Si el cable flexible o cordón de esta luminaria está dañado, debe sustituirse por un cable flexible o cordón especial que suministre exclusivamente el fabricante o su servicio técnico.

**EN** Power cord type-Y. If the flexible cable or cord of this luminaire is damaged, it must be replaced with a flexible cable or a special cord exclusively supplied by the manufacturer or its technical support.

**FR** Le câble d'alimentation type Y. Si le câble flexible ou le cordon de ce luminaire est endommagé, vous devez le remplacer par un câble flexible ou un cordon spécial qui est fourni uniquement par le fabricant ou par son département technique.

**DE** Anschlussleitung Typ Y. Wenn die flexible Leitung dieser Leuchte beschädigt ist, muss es mit einem flexiblen Kabel oder einem Spezialkabel ausschließlich vom Hersteller oder dessen technischen Support versorgt ersetzt werden.

**LEC**  
Light Environment Control

Polígono Industrial El Olivar, Calle Copejadores Nº 2 · 11160 Barbate (Cádiz) España-Spain

Tel.: +34 956 454 130

info@lecsl.com | www.lecsl.com



“Empresa certificada en diseño y fabricación de luminarias”

www.lecsl.com

Rev. 2 200617



**LEC**  
Light Environment Control

## VALENTINA HS VERSO

### INSTRUCCIONES DE MONTAJE

### MOUNTING INSTRUCTIONS

### MONTAGEANLEITUNG

### INSTRUCTIONS DE MONTAGE



Serie	Maintenance	Power	Weight	Temp
Valentina HS Verso VA.HS.V.03000	A:Ø380 B:479 H:194	19W	5,3 Kg	Tc 75°C
Valentina HS Verso VA.HS.V.04000	A:Ø380 B:479 H:194	26W	5,3 Kg	Tc 75°C
Valentina HS Verso VA.HS.V.06000	A:Ø380 B:479 H:194	39W	5,3 Kg	Tc 75°C
Valentina HS Verso VA.HS.V.08000	A:Ø380 B:479 H:194	52W	5,3 Kg	Tc 75°C
Valentina HS Verso VA.HS.V.11000	A:Ø380 B:479 H:194	76W	5,3 Kg	Tc 75°C



Driver	Ref.	Voltage	Frequency	Ambient Temp	Case Temp
DRIVER (VA.HS.V.03000)	LECTRD0020CFNT000	198-264V	50/60 Hz	Tw 80°C	Tc 75°C
DRIVER (VA.HS.V.04000)	LECTRD0045CFNT001	198-264 V	50/60 Hz	Tw 80°C	Tc 75°C
DRIVER (VA.HS.V.06000)	LECTRD0045CFNT001	198-264 V	50/60 Hz	Tw 80°C	Tc 75°C
DRIVER (VA.HS.V.08000)	LECTRD0060CFNT003	198-264 V	50/60 Hz	Tw 80°C	Tc 75°C
DRIVER (VA.HS.V.11000)	LECTRD0100CFNT004	198-264 V	50/60 Hz	Tw 80°C	Tc 75°C



AC 198-264 V  
50/60 Hz

www.lecsl.com

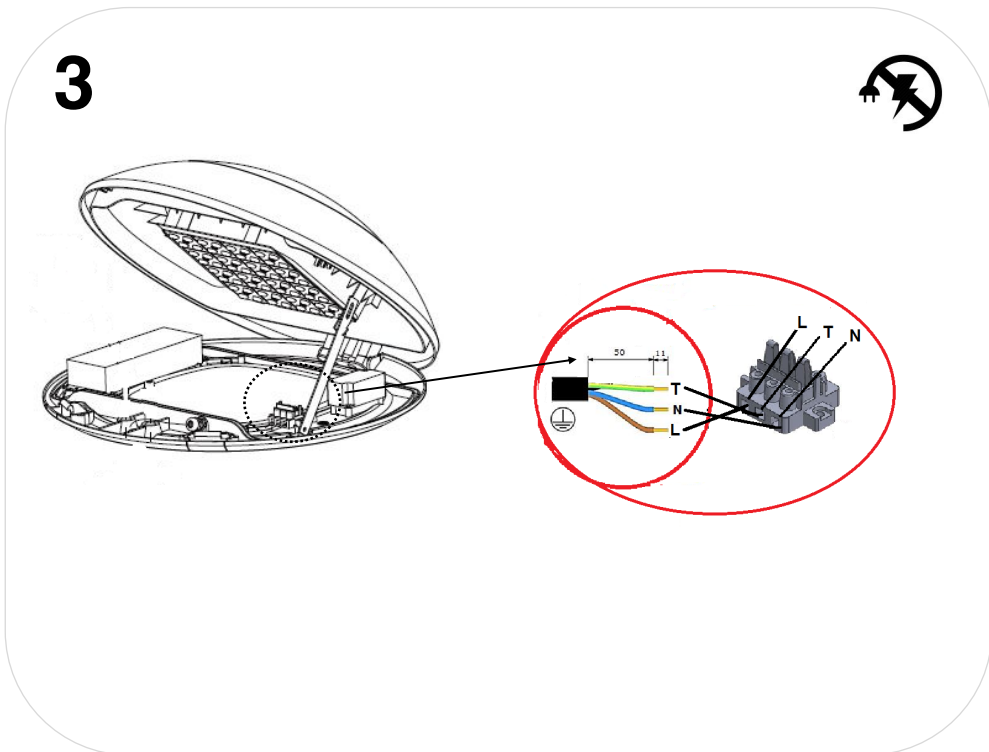
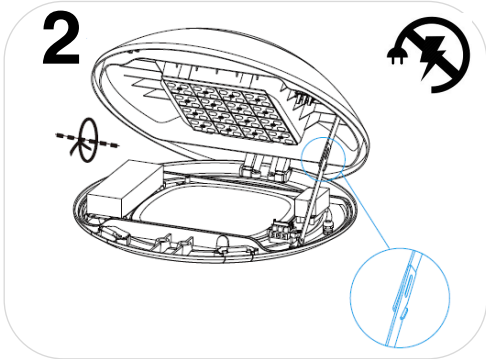
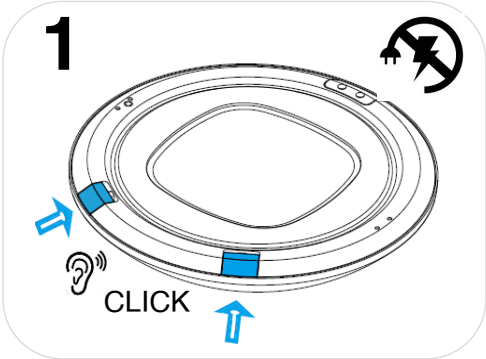
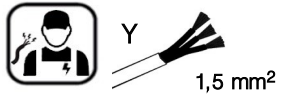

- Precaución, riesgo de choque eléctrico
- Caution, electrical risks
- Attention, risque de choc électrique

